

# PSO-Optimized FOPID Controller for Electric Vehicle: Comparative study

N. Touhami<sup>1</sup>, Smail Mansouri<sup>2</sup> and Omar Ouled-Ali<sup>3</sup>

<sup>(1)</sup>LDDI Laboratory Ahmed Draia University, Adrar, Algeria

<sup>(2)</sup>LEESI Laboratory Ahmed Draia University, Adrar, Algeria

<sup>(3)</sup>LDDI Laboratory Ahmed Draia University, Adrar, Algeria

Email of the corresponding author: [touhami.nawal@univ-adrar.edu.dz](mailto:touhami.nawal@univ-adrar.edu.dz)

**Abstract**—This research conducts a comparative evaluation of a conventional Proportional-Integral-Derivative (PID) controller and a Fractional Order PID (FOPID) controller, enhanced through the Particle Swarm Optimization (PSO) algorithm, for a Two-Wheel Drive Electric Vehicle (TWDEV) equipped with an electronic differential. The electronic differential plays a crucial role in distributing torque to the wheels based on speed and road conditions, ensuring smooth cornering and improved vehicle maneuverability. The performance evaluation is carried out through simulations in MATLAB/Simulink. The PSO-optimized FOPID controller outperforms the conventional PID by preventing overshoot, reducing torque peak, and minimizing torque ripple under varying conditions. Its adaptability enhances vehicle handling, traction control, and efficiency, improving TWDEV performance and driving comfort.

**Keywords**—Two-Wheel Drive Electric Vehicle (TWDEV), Electronic Differential (ED), Fractional Order PID (FOPID) Controller, Particle Swarm Optimization (PSO)

## I. INTRODUCTION

In recent years, the demand for electric vehicles (EVs) has significantly increased, driven mainly by the urgent necessity to lower greenhouse gas (GHG) emissions [1]. Electric machines are a crucial component of EV drivetrains, with permanent magnet machines becoming increasingly prevalent in modern traction propulsion systems [2].

Field-Oriented Control (FOC), commonly known as vector control, is a widely adopted method for electric machine drive control and is recognized for significantly improving the performance of PMSM drives [3,4]. According to W. Ahmed *et al.* [9], FOC is among the most prevalent control strategies in electric drive systems, as it enhances PMSM operation and simplifies speed control by decoupling the torque-producing component from the flux component [4,5].

The industrial sector has increasingly demanded more accurate and sophisticated control techniques, prompting a shift from conventional PID controllers to fractional-order PID (FOPID) controllers. Owing to their higher reliability, improved efficiency, and superior performance in complex

applications, FOPID controllers have attracted growing attention [6]. Moreover, Y. Ahmed *et al.* [7] improved FOPID performance by applying metaheuristic optimization, demonstrating that this approach significantly enhanced the drive system's dynamic response and control accuracy compared with traditional PID controllers.

Particle Swarm Optimizer (PSO) is a fundamental optimization technique that can effectively solve a wide range of problems, delivering high-quality solutions with minimal computational effort [8]. For instance, S. S. A. Naqvi *et al.* [9] proposed a PSO-optimized PI controller for regulating EV motor speed, demonstrating improved tracking performance and control precision by minimizing the mean squared error (MSE) between the desired and actual speed profiles.

In EVs, the electronic differential system plays a crucial role in ensuring smooth vehicle operation. It adjusts wheel speeds based on road curvature, ensuring that the inner wheel rotates slower than the outer wheel to maintain stability and maneuverability [10].

This study aims to enhance the control efficiency of Two-Wheel Drive Electric Vehicle (TWDEV) using PSO-

## PSO-Optimized FOPID Controller for Electric Vehicle: Comparative study

Optimized FOPID controller by incorporating an electronic differential.

The structure of this paper is organized as follows: Section 1 explores the field-oriented control (FOC) of PMSM. Section 2 provides a summary of PID and FOPID controllers, while Section 3 describes the electronic differential system. Section 4 delves into the PSO algorithm. Section 5 presents the analysis of the results and findings of the proposed control methods. Lastly, Section 6 concludes the study.

### II. FOC OF PMSM

The mathematical representation of the PMSM is expressed through the following equations [11]:

$$V_d = R_s I_d + \frac{d\phi_d}{dt} - \omega_r \phi_q \quad (1)$$

$$V_q = R_s I_q + \frac{d\phi_q}{dt} + \omega_r \phi_d \quad (2)$$

$$T_e = \frac{3P}{2} (\phi_d I_q - \phi_q I_d) \quad (3)$$

$$\phi_d = L_d I_d + L_m I_f \quad (4)$$

$$\phi_q = L_q I_q \quad (5)$$

Field-Oriented Control (FOC) is a crucial method for controlling Permanent Magnet Synchronous Motors

(PMSMs) by maintaining an optimal 90° angle between stator and rotor flux to maximize torque. The process involves measuring three-phase currents and rotor angle, converting them into a two-phase stationary reference frame using Clarke transformation, and further transforming them into a rotating frame with Park transformation. By keeping the direct axis current ( $I_d$ ) minimal and maximizing the quadrature axis current ( $I_q$ ), the control system ensures efficient torque generation. The corrected voltages are then transformed back to three-phase form and applied to the inverter for motor control [12].

The main parameters of the PMSM used in this study are summarized in Table 1 [13].

TABLE I. PMSM PARAMETERS

Parameter	Value
Stator resistance $R_s$ ( $\Omega$ )	1.4
d-axis inductance $L_d$ (H)	0.0066
q-axis inductance $L_q$ (H)	0.0058
Moment of inertia J ( $\text{kg}\cdot\text{m}^2$ )	0.00176
Friction coefficient ( $\text{N}\cdot\text{m}\cdot\text{s}/\text{rad}$ ) f	0.00038
Number of pole pairs P	3

Figure (1) presents the fundamental block diagram of the FOC strategy for a PMSM.

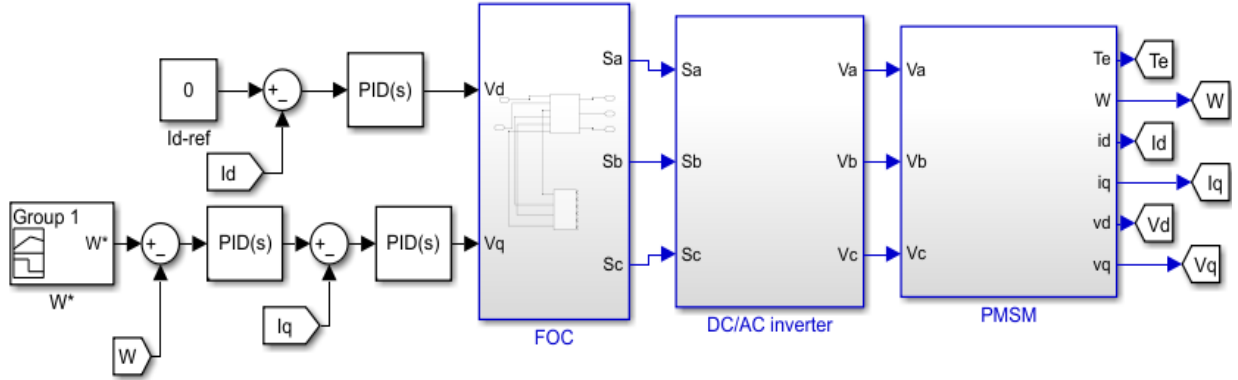

Fig. 1. Matlab block diagram of FOC for PMSM.

### III. PID AND FOPID CONTROLLERS

The traditional PID controller comprises three components: proportional, integral, and derivative. Its control law is expressed as follows [14,15]:

$$U(t) = K_p e(t) + K_i \int e(t) dt + K_d \frac{de(t)}{dt} \quad (6)$$

The FOPID controller is an advanced version of the conventional PID controller, allowing integration and differentiation to be performed in arbitrary orders. The time-domain differential equation for the FOPID controller is given as follows [15-17]:

$$U(t) = K_p e(t) + \frac{K_i}{s^\lambda} e(t) + K_d s^\mu e(t) \quad (7)$$

### IV. ELECTRONIC DIFFERENTIAL SYSTEM

Recently, the electronic differential (ED) system has become the preferred alternative to traditional mechanical differentials owing to significant benefits like lower weight

and lower energy losses. As the wheels are not mechanically connected, the controller allocates traction power to each wheel independently [18, 19]. The outer wheel needs to spin at a higher speed than the inner wheel according to the turning angle. When the EV moves in a straight line, the steering angle remains zero, whereas any deviation in the steering angle causes the vehicle to turn left or right [19].

The angular speed for each wheel drive is defined as [20]:

$$\begin{cases} \omega_r = \left( \frac{L_\omega + \frac{1}{2} d_\omega \tan(\delta)}{L_\omega} \right) \omega_v \\ \omega_l = \left( \frac{L_\omega - \frac{1}{2} d_\omega \tan(\delta)}{L_\omega} \right) \omega_v \end{cases} \quad (8)$$

Where  $L_\omega$  represents the wheelbase,  $d_\omega$  is the separation between the wheels on the same axle,  $\delta$  represents the steering angle,  $\omega_r$  and  $\omega_l$  are the angular speed of the right and left wheel drives, respectively.

V. PARTICLE SWARM OPTIMIZATION (PSO)

Kennedy and Eberhart initially proposed Particle Swarm Optimization (PSO) in 1995 [21, 22].

A swarm may appear as a chaotic collection of elements, but it operates based on collective intelligence to accomplish tasks such as evading predators or locating food. In optimization problems, these swarm elements act as abstract particles that navigate the search space to identify the optimal solution. Initially, particles are randomly distributed and iteratively adjust their positions by balancing two key behaviors: exploration, based on their own best-found position, and exploitation, influenced by the best position within their neighborhood. This synergy enables efficient optimization by combining individual learning with collective convergence toward the best solution [23].

The governing equations of the standard PSO algorithm are given as follows [22, 24]:

$$v_i^{t+1} = \omega v_i^t + c_1 r_1 (p_{best(i)}^t - x_i^t) + c_2 r_2 (g_{best}^t - x_i^t) \quad (9)$$

$$x_i^{t+1} = x_i^t + v_i^{t+1} \quad (10)$$

Where:  $v_i^{t+1}$  and  $x_i^{t+1}$  are the velocity and the location of particle  $I$  at the  $(t + 1)^{th}$  iteration,  $\omega$  is the inertia weight of a particle,  $v_i^t$  and  $x_i^t$  represent the speed and the location in the  $t^{th}$  iteration of particle  $I$ ,  $p_{best(i)}^t$  and  $g_{best}^t$  are the individual and global best position of the particle  $I$  in the  $t^{th}$  iteration,  $c_1, c_2$  depict the actual acceleration coefficients determining the influence of the global and individual best positions on the particle's velocity,  $r_1, r_2$  represent random numbers uniformly distributed between 0 and 1. Figure (2) presents the flowchart of PSO.

VI. PROPOSED TWO-WHEEL DRIVE ELECTRIC VEHICLE

This study examines a Two-Wheel Drive Electric Vehicle featuring an electronic differential. Field-Oriented Control (FOC) with PID controllers is first implemented, followed by an optimized FOC using FOPID controllers tuned with Particle Swarm Optimization (PSO) to regulate the torque of two Permanent Magnet Synchronous Motors (PMSMs). Each motor is independently driven by DC/AC inverters, ensuring effective traction and maneuverability. To evaluate the performance of the proposed system, both control strategies are integrated into the FOC framework for the left and right motors, with the corresponding electronic differential managing torque distribution. The MATLAB/Simulink block diagrams of these implementations are shown in Figure (3),

highlighting the differences between standard PID control and the enhanced FOPID approach.

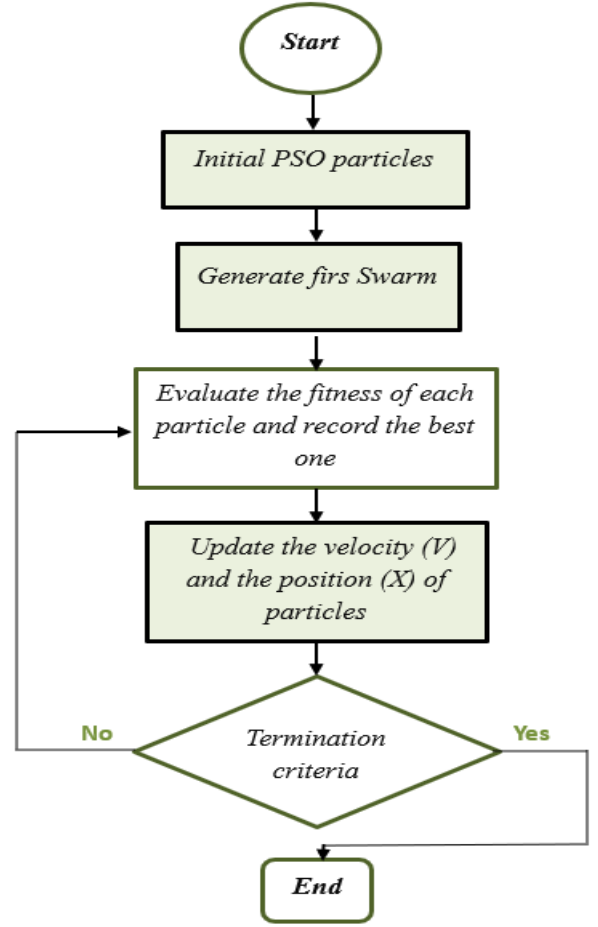
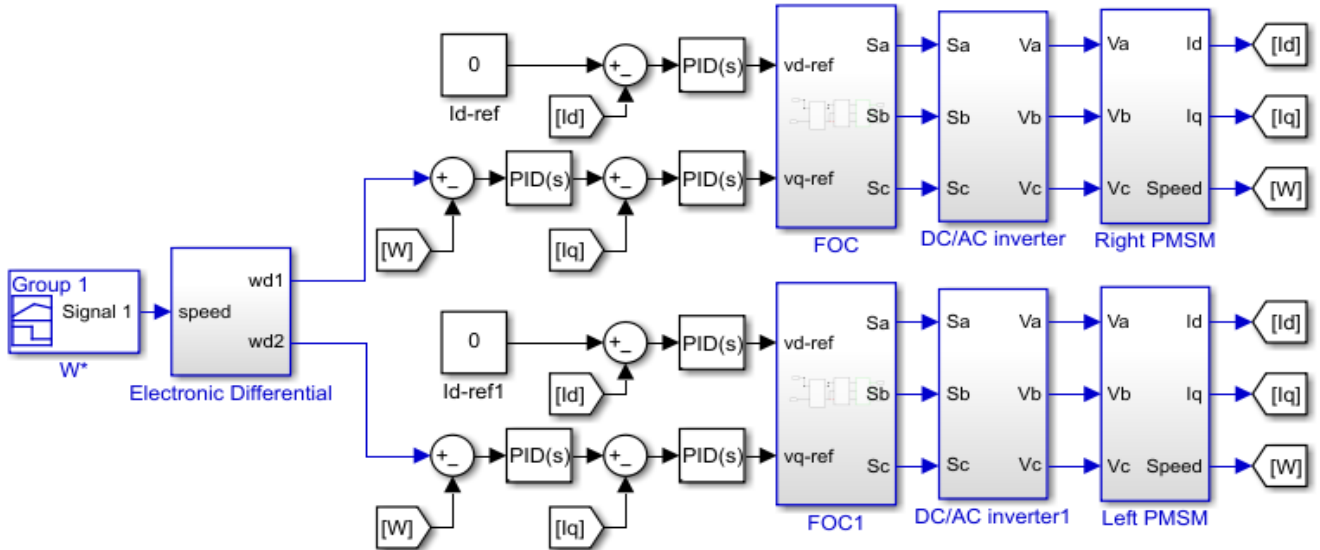

Fig. 2. PSO organigram.

Table 2 presents the values of the parameters used for the Particle Swarm Optimization (PSO).

TABLE II. THE PARAMETERS EMPLOYED IN THE PSO ALGORITHM

Parameter	Value
$c_1$ coefficient	1;5
$c_2$ coefficient	2
Inertia coefficient ( $\omega$ )	1
Population size	100
Lower bound	0
Upper bound	100
Number of iterations	100



(a)

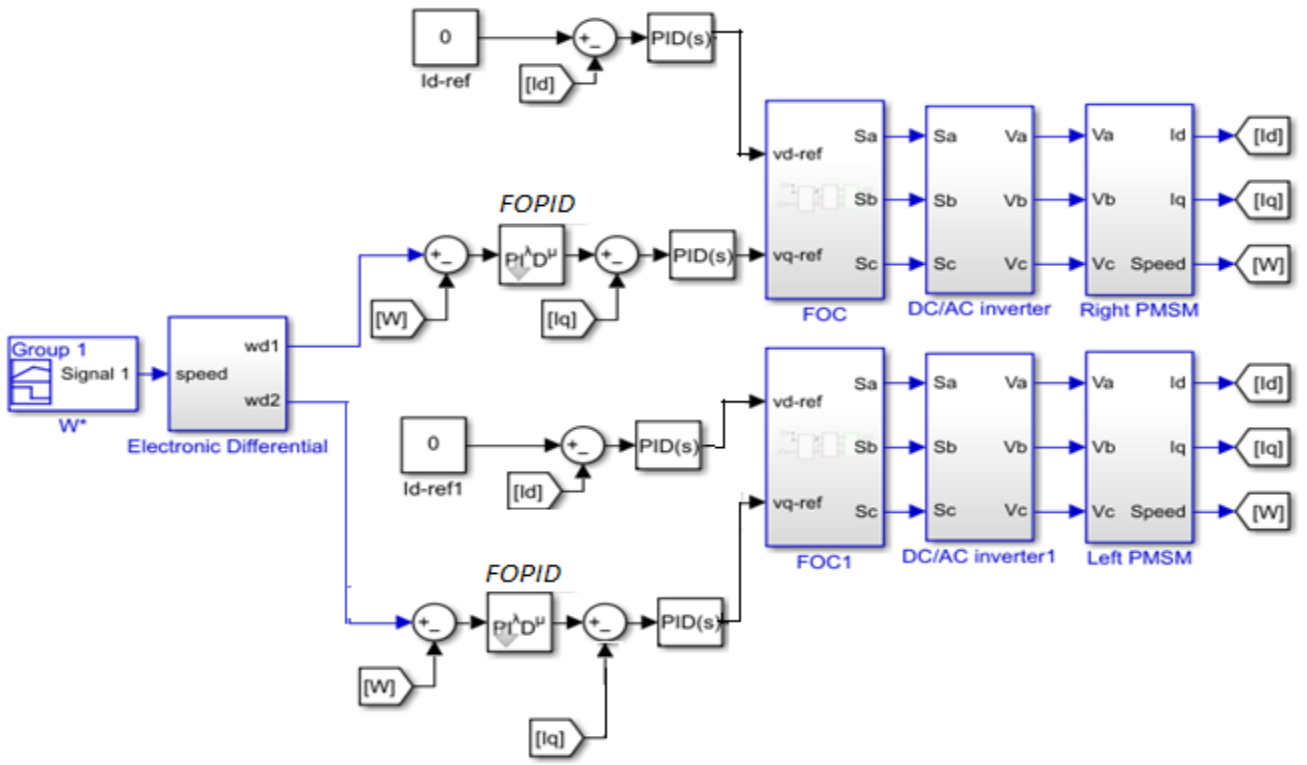

(b)

Fig. 3. Matlab bloc of the proposed TWDEV: (a) PID, (b) FOPID.

## VII. ANALYSIS AND DISCUSSION OF RESULTS

In this study, a TWDEV was simulated in MATLAB/Simulink, utilizing FOC for control through an electronic differential (ED). Initially, PID controllers were implemented, followed by FOPID controllers optimized using the PSO algorithm.

Various speed was applied to the EV with a 50° left turn at  $t = 1$  (s), and a 40° right turn at  $t = 6$  (s).

Figure (4) compares the speed results of the conventional FOC technique with PID controllers and the optimized FOC control using PSO-optimized FOPID controllers. Figure (5) presents the electromagnetic torque results for the right motor using both techniques in this study. Figure (6) depicts the current results for the right motor.

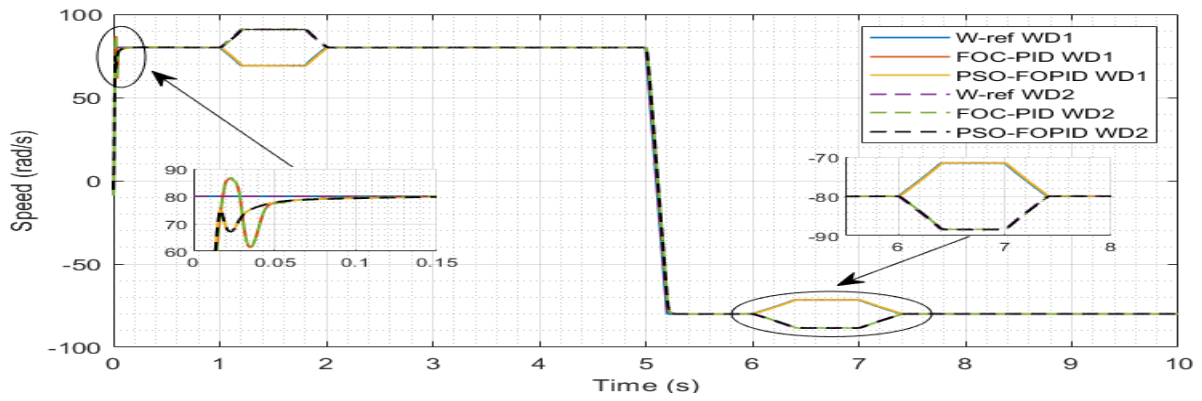

Fig. 4. Speed performances.

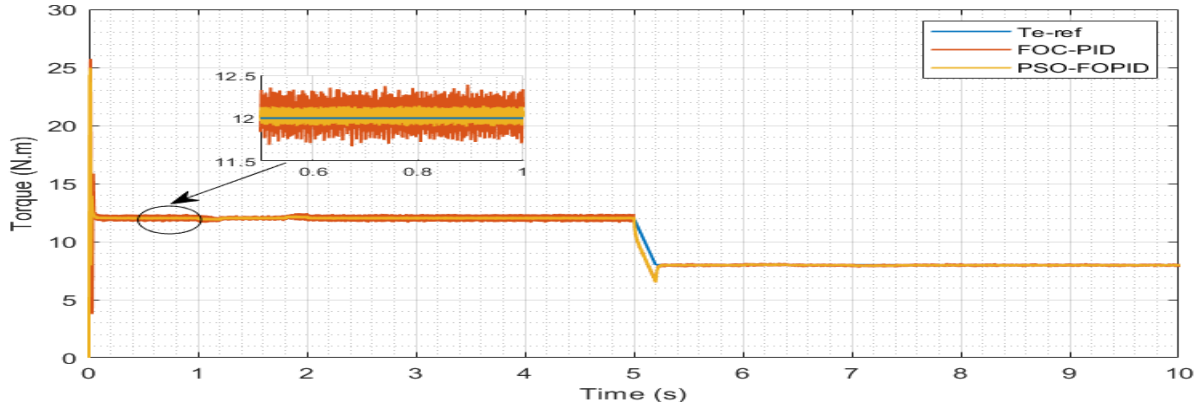

Fig. 5. Torque performances.

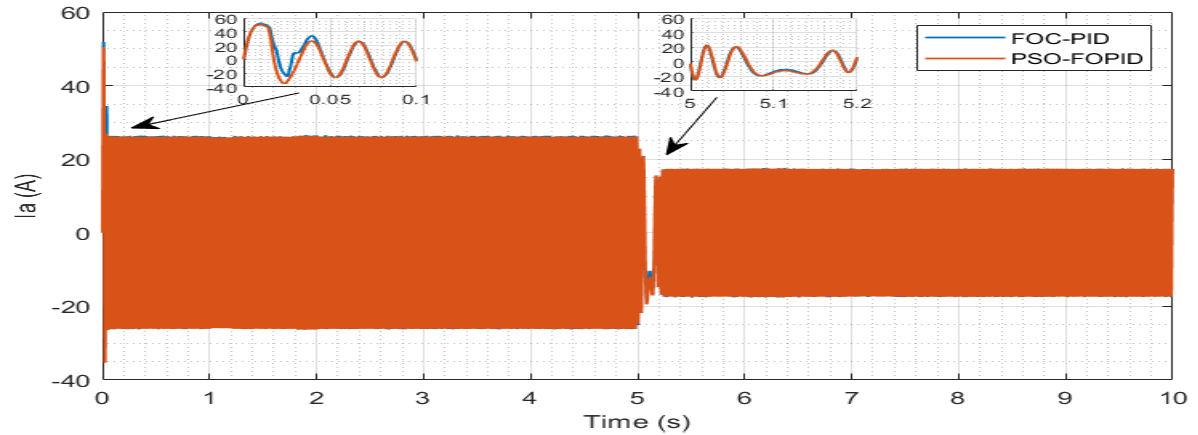

Fig. 6. Current performances

The comparison between FOC with PID controllers and FOPID controllers optimized using PSO shows that FOPID-PSO significantly enhances performance in TWDEV. It effectively reduces the maximum speed ripple from 0.38 rad/s (FOC) to 0.12 rad/s and the maximum torque ripple from 0.40 N·m to 0.10 N·m, resulting in smoother operation. Moreover, FOPID-PSO completely eliminates overshoot, whereas FOC experiences a 7 rad/s overshoot, leading to improved speed stability.

These findings confirm that FOPID-PSO provides better speed regulation, reduces mechanical stress, and enhances overall driving performance compared to traditional FOC with PID controllers.

## VIII. CONCLUSION

The comparative analysis of FOC with PID controllers and PSO-optimized FOPID controllers for a TWDEV demonstrates the superiority of the FOPID-PSO approach. The significant reduction in speed and torque ripples ensures smoother operation, minimizing mechanical stress on the drivetrain. Furthermore, the complete elimination of overshoot improves speed stability, which is critical for enhancing vehicle control and driving comfort. These results confirm that the integration of FOPID-PSO control in TWDEV systems leads to improved performance, making it a viable alternative to conventional FOC strategies for achieving higher efficiency, stability, and ride quality.

# PSO-Optimized FOPID Controller for Electric Vehicle: Comparative study

## REFERENCES

- [1] Ahmed Abd El Baset Abd El Halim, Ehab Hassan Eid Bayoumi, Walid El-Khattam, and Amr Mohamed Ibrahim, "Electric vehicles: a review of their components and technologies", *International Journal of Power Electronics and Drive Systems (IJPEDS)*, Vol. 13, No. 4, 2022. <http://doi.org/10.11591/ijpeds.v13.i4.pp2041-2061>
- [2] Emmanuel Agamloh, Annette von Jouanne, and Alexandre Yokochi, "An overview of electric machine trends in modern electric vehicles. Machines", v. 8, no. 2, machines, 2020. <https://doi.org/10.3390/machines8020020>
- [3] K. Boby, A.M. Kottalil, N.P. Ananthamoorthy, Mathematical modelling of pmsm vector control system based on SVPWM with pi controller using Matlab, *International Journal of Advanced Research in Electrical, Electronics and Instrumentation Engineering*. E-ISSN: 2278 – 8875, Vol.2, Issue 1, pp. 689-695, january 2013.
- [4] AHMED, W.A.E.M.; ADEL, M.M.; TAHA, M.; SALEH, A.A, "PSO technique applied to sensorless field-oriented control PMSM drive with discretized RLfractional integral", *Alexandria Engineering Journal*, v. 60, Issue 4, pp. Pages 4029-4040, 2021. <https://doi.org/10.1016/j.aej.2021.02.049>
- [5] ] L. Saihi, A. Bouhenna, M. Chenafa, A. Mansouri, "A robust sensorless SMC of PMSM based on sliding mode observer and extended Kalman filter", *Proc. 4th International Conference on Electrical Engineering (ICEE)*, Boumerdes, Algeria, 2015, pp. 1-4, doi: 10.1109/INTEE.2015.7416838.
- [6] Adeel Ahmad Jamil, Wen Fu Tu, Syed Wajhat Ali, Yacine Terriche , and Josep M. Guerrero, "Fractional-Order PID Controllers for Temperature Control: A Review", *Energies*, Vol. 15, Issue 10, 2022. <https://doi.org/10.3390/en15103800>
- [7] Y. Ahmed, A. Hoballah, E. Hendawi, S. Al Otaibi, S. K. Elsayed, N. I. Elkalashy, "Fractional order PID controller adaptation for PMSM drive using hybrid grey wolf optimization," *International Journal of Power Electronics and Drive System (IJPEDS)*, Vol. 12, No. 2, 2021, pp. 745-756 ISSN: 2088-8694, doi: 10.11591/ijpeds.v12.i2.pp745-756.
- [8] Eka Marlina, Arif Wahjudi, Latifah Nurahmi, I Made Londen Batan, and Guowu Wei, "Optimizing the Tuning of Fuzzy-PID Controllers for Motion Control of Friction Stir Welding Robots", *Journal of Robotics and Control (JRC)*, Volume 5, Issue 4, 2024. <https://doi.org/10.18196/jrc.v5i4.21697>
- [9] Naqvi S.S.A., Jamil H., Iqbal N., Khan S., Lee D.-I., Park Y.C., Kim D.H., Multi-objective optimization of PI controller for BLDC motor speed control and energy saving in electric vehicles: A constrained swarm-based approach, *Energy Reports*, (2024).
- [10] Merve Yldrm, Eyyüp Öksüztepe, Burak Tanyeri, and Hasan Kürüm, "Electronic Differential System for an Electric Vehicle with In-Wheel Motor", in *Proc. 9th International Conference on Electrical and Electronics Engineering (ELECO)*, Bursa, Turkey, pp. 1048-1052, 2015, doi: 10.1109/ELECO.2015.7394567.
- [11] M. Yeri Veeresh, V. Naga Bhaskar Reddy, and R. Kiranmayi, "Modeling and Analysis of Time Response Parameters of a PMSM-Based Electric Vehicle with PI and PID Controllers", *Engineering, Technology & Applied Science Research*, Vol. 12 No. 6, pp. 9737-9741, December, 2022. <https://doi.org/10.48084/etasr.5321>
- [12] P. Ramesh, M. Umavathi, C. Bharatiraja, G. Ramanathan, Sivaprasad Athikkal, "Development of a PMSM motor field-oriented control algorithm for electrical vehicles", *Materials Today*, Volume 65, Part 1, pp. 176-187, 2022.. <https://doi.org/10.1016/j.matpr.2022.06.080>
- [13] B. Sebti, O. Bouakaz, B. Zegueb, and F. Naceri, "Robust Direct Torque and Flux Control of Adjustable Speed Sensorless PMSM", *International Conference on Electronics & Oil: from theory to applications (ICEO'11)*, 2011.
- [14] P. T K, V. Yadav, V. K. Tayal, and P. Choudekar, "PID control design for a temperature control system", In *Proc. International Conference on Power Energy, Environment and Intelligent Control (PEEIC)*, Greater Noida, India, pp. 632-637, 2018, doi: 10.1109/PEEIC.2018.8665469.
- [15] Mohamed Jasim Mohamed, and Luay Thamir Rasheed, "Design of Nonlinear PID and FOPID Controllers for Electronic Throttle Valve Plate's Position", *Journal of Electrical and Computer Engineering*, pp :1-17, June 2024. <https://doi.org/10.1155/2024/9984750>
- [16] R. H. Ghobashy, M. M. I. Ali, and M. A. M. Hassan, "Voltage regulation of PV system connected to grid based on FOPID controllers using evolutionary computational techniques", *Twentieth International Middle East Power Systems Conference (MEPCON)*, Cairo, Egypt, 2018, pp. 33-38, doi: 10.1109/MEPCON.2018.8635121.
- [17] P. D. Dewangan, V. P. Singh, and S. L. Sinha, "Design of FOPID controller for higher order continuous interval system using improved approximation ensuring stability," *SN Applied Science*. Vol. 3, Art. N° 493, 2021. <https://doi.org/10.1007/s42452-021-04492-w>
- [18] W. Khan-Ngern and W. Keyoonwong, "Embedded electronic differential system on two brushless DC motor drives for electric vehicle steering control", *IEEE International Conference on Embedded Systems and Intelligent Technology & International Conference on Information and Communication Technology for Embedded Systems (ICESIT-ICICTES)*, Khon Kaen, Thailand, pp. 1-4, 2018, doi: 10.1109/ICESIT-ICICTES.2018.8442060.
- [19] Merve Yldrm, and Hasan Kürüm, "Electronic Differential System for an Electric Vehicle with Four In-wheel PMSM", *IEEE 91st Vehicular Technology Conference (VTC2020-Spring)*, Antwerp, Belgium, pp. 1-5, 2020, doi: 10.1109/VTC2020-Spring48590.2020.9129139.
- [20] Kada Hartani, Mohamed Bourahla, Yahia Miloud, Mohamed Sekour, "Electronic Differential with Direct Torque Fuzzy Control for Vehicle Propulsion System", *Turk J Elec Eng & Comp Sci*, Vol.17, No.1, 2009, TUBITAK, doi:10.3906/elk-0801-1
- [21] KENNEDY, J.; EBERHART, R. "Particle Swarm Optimization", *Proceedings of IEEE International Conference on Neural Networks*, IEEE Press: Piscataway, NJ, USA, pp. 1942-1947, Perth, WA, Australia, 1995.
- [22] Touhami Nawal, Ouled-Ali Omar, and Mansouri Smail, "Enhanced dynamics of sensorless two-wheel drive electric vehicles through electronic differential and advanced metaheuristic algorithms", *Studies in Engineering and Exact Sciences*, Vol. 5, N° 2, 2024. pp. 01-22, <https://doi.org/10.54021/seesv5n2-718>
- [23] Francesca Pace, Alessandro Santilano, and Alberto Godio, "A Review of Geophysical Modeling Based on Particle Swarm Optimization", *Surveys in Geophysics*, Vol. 42, pp. 505-549, 2021. <https://doi.org/10.1007/s10712-021-09638-4>
- [24] GAD, A.G. "Particle Swarm Optimization Algorithm and Its Applications : A Systematic Review", *Archives of Computational Methods in Engineering*, Vol. 29, pp. 2531-2561, 2022. <https://doi.org/10.1007/s11831-021-09694-4>.